



Light Gate

(Product No. 3250)

 **DATA HARVEST**

Data Harvest Group Ltd.
1 Eden Court, Leighton Buzzard,
Beds, LU7 4FY
Tel: 01525 373666
Fax: 01525 851638
e-mail: sales@data-harvest.co.uk
www.data-harvest.co.uk

DS 054

No 4

Contents

Introduction	2
Connecting.....	2
Measurement procedure	3
Investigations.....	3
Timing investigations	3
Sensing investigations.....	6
Practical information	7
Specifications.....	9
Additional Accessories for use with Light Gates	9
Limited warranty	9

Introduction

The *Smart Q* Light Gate is a digital switch-type sensor that has two states low (ON condition) and high (OFF condition). The Light Gate comprises an infrared transmitter and a receiver mounted and aligned in a plastic frame.

A Light Gate can be used singly or in pairs to provide timing and event monitoring. Solid bodies breaking the beam between the transmitter and receiver allow **EASYSense** to detect the elapsed time for individual events or a series of events.

The Light Gate is supplied with a steel support rod (80 mm long x 10 mm diameter with a M6 thread). This support rod can be screwed into the mounting threads, which are found at the base and sides of the Light Gate. The rod can be used for clamping into a suitable holding device.

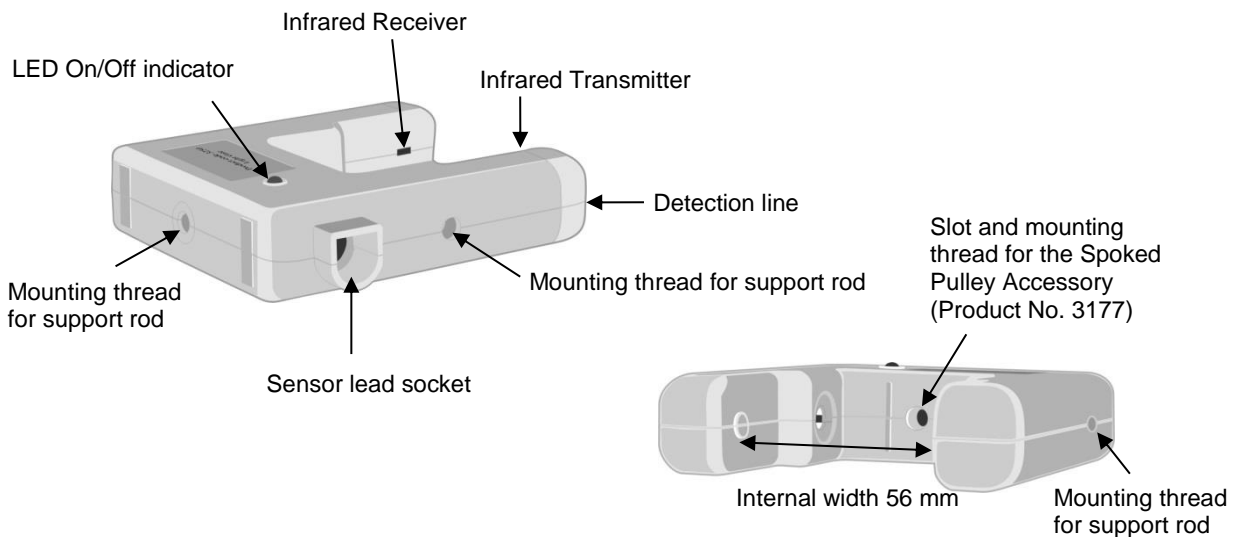

Connecting

For **Timing** operations with only one Light Gate, the gate must be connected to the input labelled **A**. If two Light Gates are used they should be connected to the inputs labelled **A** and **B**.

If used to record non-Timing data e.g. when used to record with Graph mode, a Light Gate can be connected to any input.

- Connect one end of the sensor cable (supplied with the **EASYSense** unit) to the input socket on the **EASYSense** unit.
- Connect the other end of the sensor cable to the shaped socket on the Light Gate.

- The **EASYSense** unit will detect that the Light Gate is connected and will either show as On/Off or as a percentage value, depending on the mode used.

Once powered by the **EASYSense** unit, the On/Off indicator on the body of the Light Gate can be used to show its signal status. The red LED will light when the infrared beam is blocked.

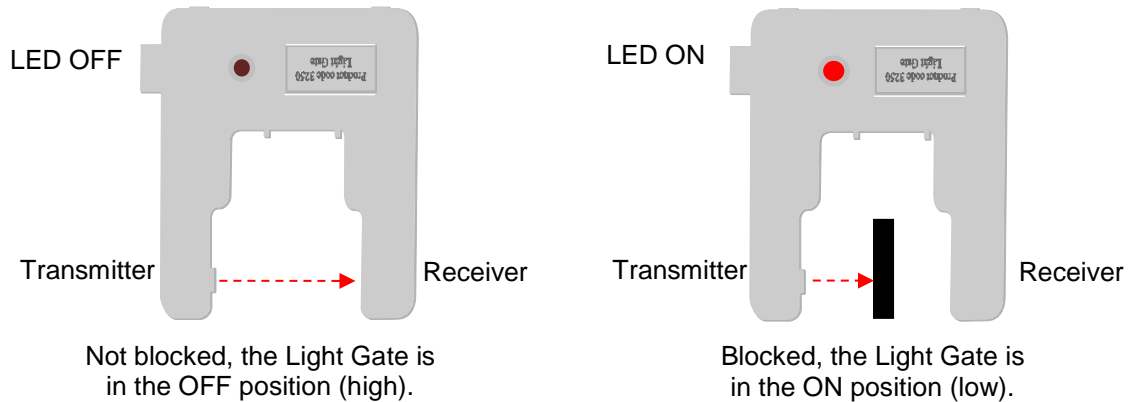

Note: If the **EASYSense** unit is in 'sleep' mode (LCD display blank), the Light Gate will not be powered and the On/Off indicator will not light. Press any button to 'wake up' the unit and power the Light Gate.

Measurement procedure

Screw the support rod into the appropriate mounting thread and clamp to a stand.

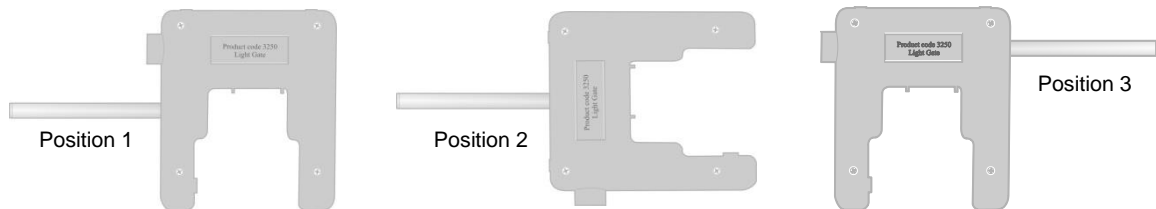

Position so the object will block the infrared beam when it passes through the Light Gate.

Investigations

- Dynamics experiments involving calculating time, speed, velocity, acceleration using inclined planes and air track
- Acceleration due to gravity investigations
- Pendulum investigations
- Measure the time period of an oscillating body
- Used with the Force sensor to investigate: Impulse and change in momentum and centripetal force in a pendulum

Timing investigations

Probably the most common use of Light Gates is in timing experiments. Measurements can be taken from either a single Light Gate connected to **Input A** or from two Light Gates connected to both **Input A** and **B**.

Timing is started when the infrared beam at Input A is blocked T_0 (the logic level changes from 0 to 1). When the infrared beam is unblocked its logic state changes back to 0 and the

time interval is stored as T_1 . If a Light Gate is connected to Input B then the time its infrared beam is blocked is stored as (T_2) and when it's unblocked as T_3 .

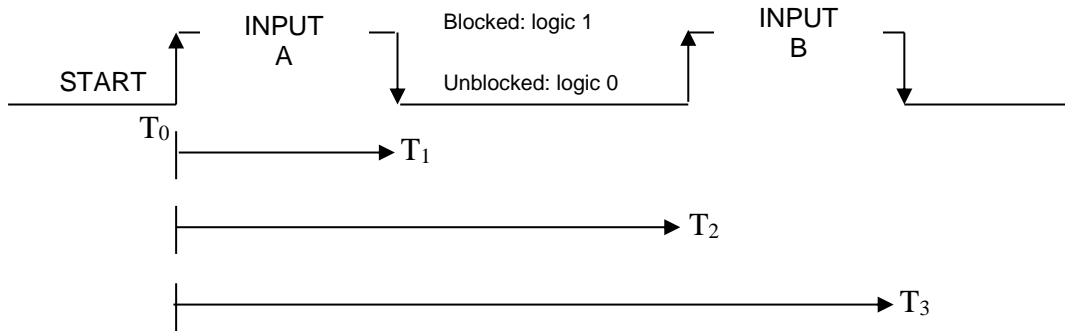

Parameters

The parameters used in an investigation need to be entered in the Timing Wizard to enable calculations for Speed/Velocity, Acceleration, Distance, Momentum and Kinetic Energy to be made from time intervals.

The parameters should be measured **accurately** and this value entered in the Timing Wizard. Errors caused by inaccurate measurements are far more significant than timing errors.

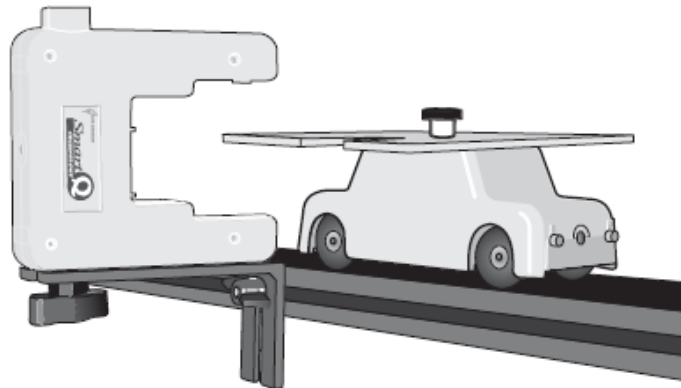

This Light Gate is shown attached to the Dynamics System track. An interrupt card is attached horizontally to the cart so the card will pass through the Light Gate.

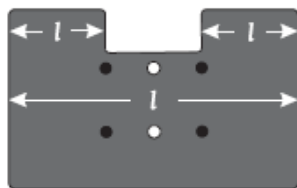

Note: The interrupt card used on the Dynamics cart has both a two segment side (double interrupt) and a solid side (single interrupt, which is aligned as appropriate for the investigation).

- A 'single' interrupt card is used when calculating Speed/Velocity at A, at A or B, at A then B, Acceleration from A to B, Momentum and Kinetic Energy at A, at A or B, at A then A, change from A to A, at A then B, change from A to B. Measure the solid part of the card that will pass through the Light Gate (in mm).

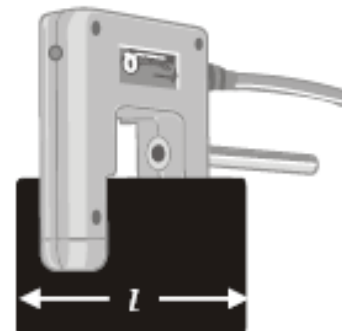

- A 'double' interrupt card is used when calculating Acceleration through A, at A or B, at A then B, change from A to B. The card is made up so that two segments will pass through the Light Gate. This allows the times T_0 , T_1 , T_2 , and T_3 to all be recorded at a single Input.

The segments **must** be equal in size and measured accurately.

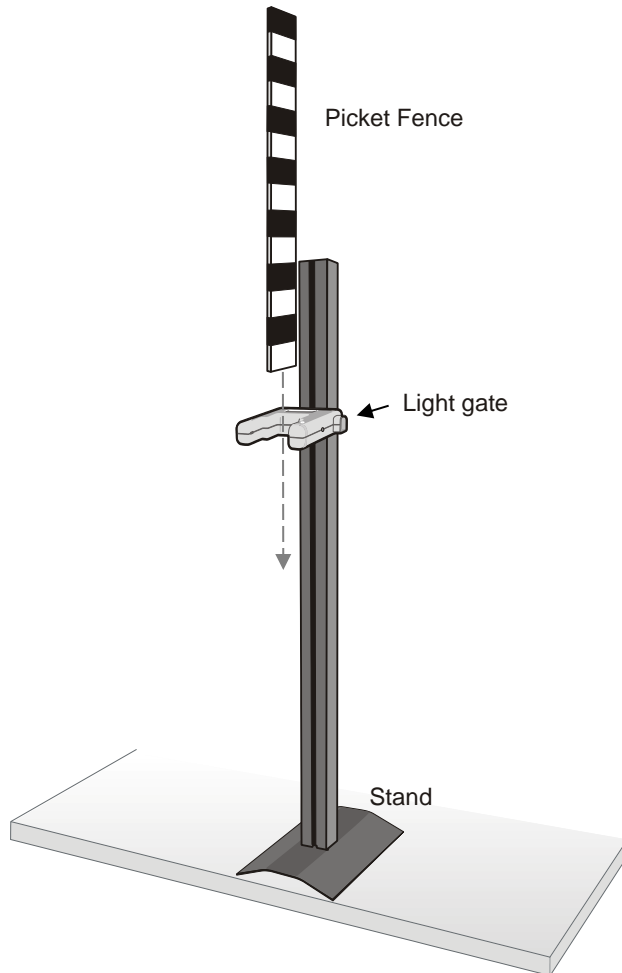
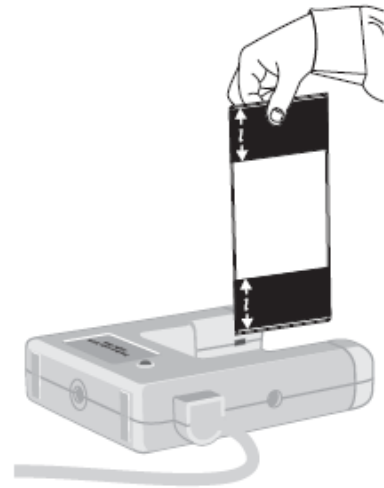

- A 'picket fence' is a multi-segmented interrupt card. It can be used to calculate Speed at A, Distance at A, Acceleration at A, Momentum and Kinetic Energy at A. Measure from the start of one black edge to the start of the next black edge.

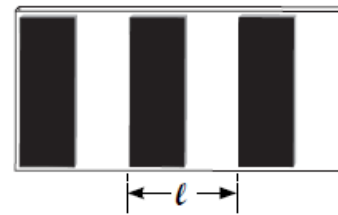

- The measurements for the Data Harvest 'spoked pulley' are pre-defined. It can be used to calculate Speed at A, Distance at A, Acceleration at A, Momentum and Kinetic Energy at A. When the Pulley rotates its spokes will block the infrared beam of the Light Gate.

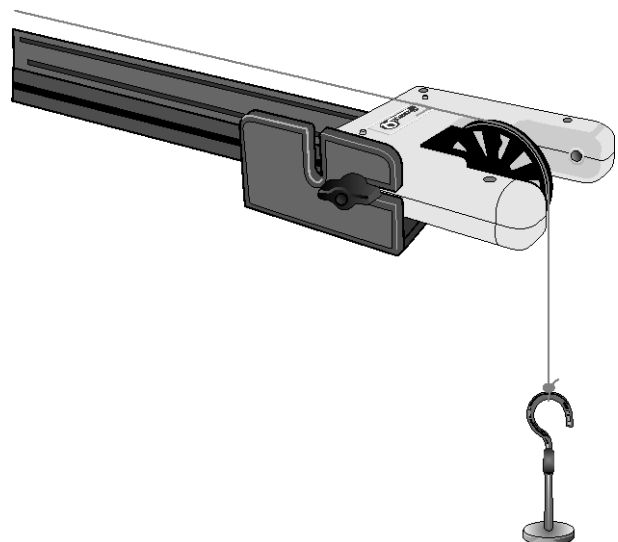

- The distance between two Light Gates is used to calculate Speed from A to B. This is best done using the detection line on each Light Gate as a marker.

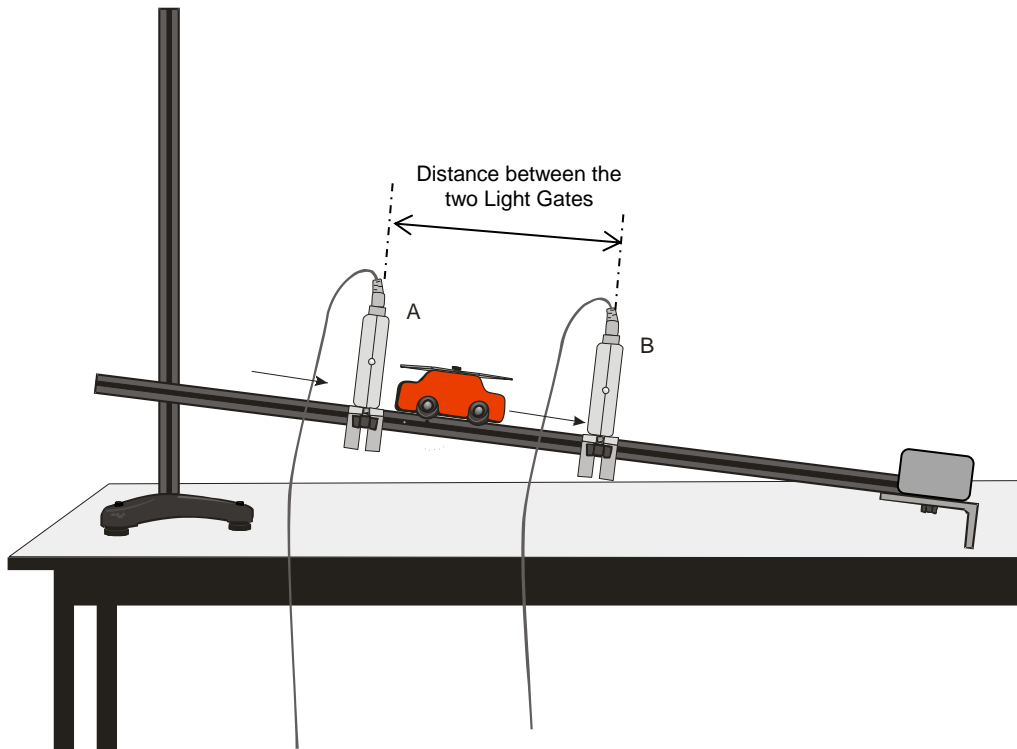

Sensing investigations

When a Light Gate is used in a non-Timing mode e.g. Graph, it will show a value of approximately 0 – 10% when the infrared beam is not blocked (OFF) and 100% when blocked (ON).

The *Smart Q* Light Gate can be connected to any input and used with the **EASYSense** software to:

1. Time the length of an event

The Light Gate can be used to calculate velocity during an investigation by using **Interval** to determine the length of time the Light Gate was interrupted.

$$\text{Velocity } V = \frac{\ell}{t_2 - t_1}$$

ℓ = length of the interrupt card
 $t_2 - t_1$ = the interval time

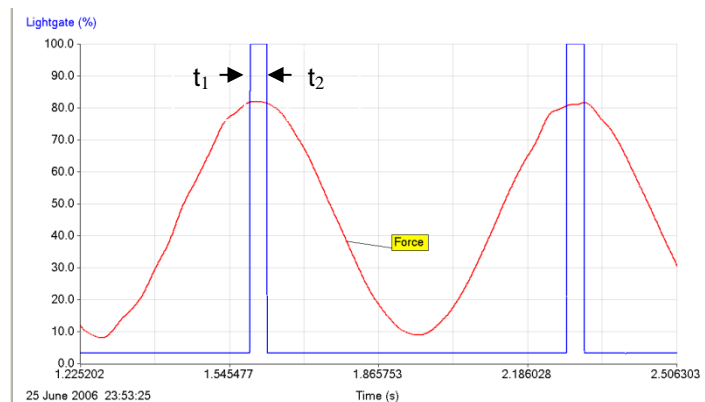

2. Mark an event on a graph

A Light Gate can be used to mark an event on a graph. Examples include:

- Measuring the heat of neutralisation in a reaction between a strong base and a strong acid. Start logging before the acid is added so the initial temperature of the base is shown on the graph. The Light Gate can be used to mark the point at which the acid is added.
- If an indicator, such as phenolphthalein, is used then the Light Gate can mark the point when the indicator changed from pink to colourless.

3. To trigger a recording

A Light Gate can be used to trigger the start of a recording if using Setup Remote or FAST recording times in Graph.

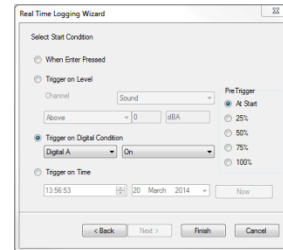

Practical information

- Measure the length of the object or interrupt card that passes through the infrared beam or the distance between two Light Gates as accurately as possible. If measurements are not accurate all the calculated data will be systematically high or low. This measurement can be the most critical part of the investigation.
- The segment length of a double interrupt card is used twice when calculating 'Acceleration at A' so any measurement error will be doubled. If two Light Gates are used to calculate acceleration - 'Acceleration from A to B' – the interrupt card's length is only used once to calculate the final velocity so the results should be more accurate.
- When measuring the distance from one Light Gate to another either measure:
 - a. From the detection line of one Light Gate to the detection line of the other
 - or
 - b. The leading edge of one Light Gate to the leading edge of the other.
- Using a long interrupt card 10 cm, may improve the accuracy of results.
- If you are measuring the diameter of an object that is going to be dropped through a Light Gate, make sure you measure the part that will actually pass through the beam.
- Clamp the Light Gate in position e.g. using the support rod supplied. Holding a Light Gate in your hand will give inaccurate results.
- When two Light Gates are used make sure they are aligned to each other (positioned in parallel, with back edges lined up so the void of one Light Gate is in line with the void of the other Gate).

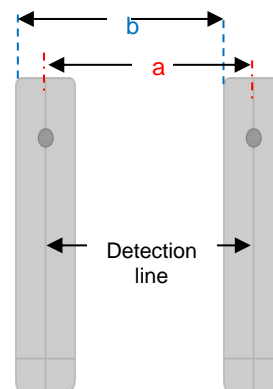

This picture shows two Light Gates attached to the Dynamics System pillar set to record Acceleration due to gravity from A to B with a single interrupt card.

- Try to arrange the set-up so the object passes as close to the receiver (the slot) as possible. This reduces any possibility of a shadow changing the effective length of the object e.g. an interrupt card.

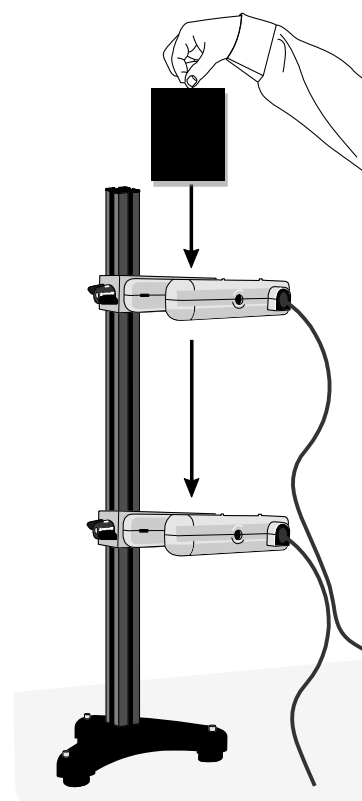

- The best material for interrupt/timing cards would be rigid, coloured black and have tidy parallel edges. Some users find that equal amounts of plasticine or Blu tack used on each of the lower corners of the interrupt card will lower the centre of gravity and make the card more stable and less likely to wobble when dropped.
- Ensure that the object/interrupt card cuts cleanly through the Light Gate's infrared beam. If it twists at all delete the result.
- Ensure that the bottom of an object (e.g. an interrupt card) does not interrupt the Light Gates beam **before** the object is released.

- If you are dropping an interrupt card through the Light Gate, hold the card centrally from the same start position just above the Gate.

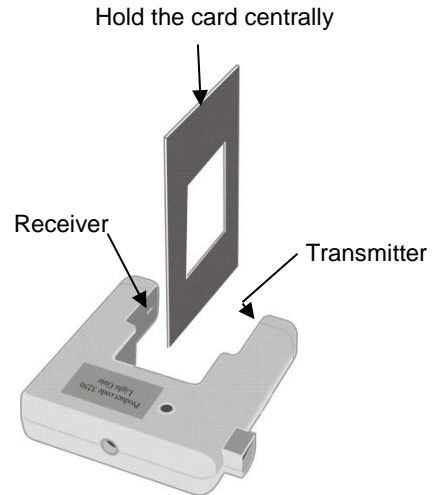

- If masses or plasticine are attached to the interrupt card make sure they do not protrude beyond the edges of the card. Masses should be balanced to prevent the card from twisting as it travels.

Example: To apply a weight of 20 g, use 2 x 10 g weights positioned at each side of the interrupt card.

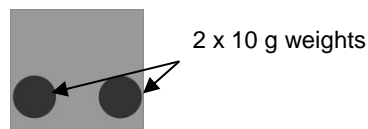

- The receiver can be sensitive to high levels of ambient infrared light or heat, shield from bright light, which can produce a false OFF result.

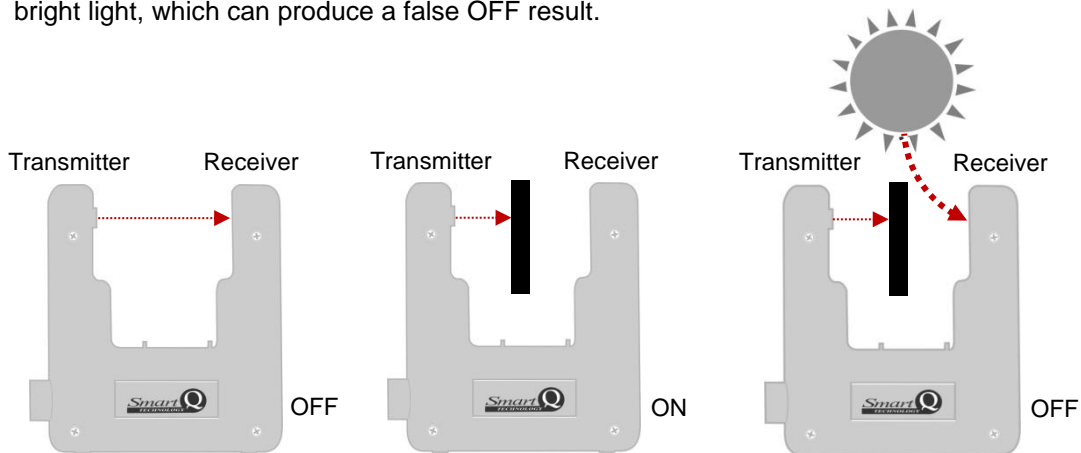

If the Light Gate is giving false OFF results try rotating through 180° (so any external light source is directed towards the transmitter) or close an appropriate blind in the room.

- The infrared LED transmitter in the Light Gates has quite high power consumption. If possible connect the **EASYSense** unit to a supply of power or ensure batteries are fully charged.

Specifications

Infrared source: Peak at 880 nm

Response time: Less than 5 microseconds.

Timing Resolution: 10 μ s

Additional Accessories for use with Light Gates

Interrupt card set

Product No. 3803

A set of three interrupt cards - single, double and multi-segmented (picket fence).

Spoked pulley

Product No. 3177

10 segment very low friction pulley which attaches to either a Light Gate or the Dynamics System.

Dynamics System

Product No. 3800

Aluminium track and support pillar, low-friction cart, spoked pulley (3177), brackets, and fixings.

Dynamics System Extension Kit 1

Product No. 3801

Low-friction cart, magnets, springs, and set of three additional interrupt cards (3803).

Limited warranty

For information about the terms of the product warranty, see the Data Harvest website at: <https://data-harvest.co.uk/warranty>

Note: Data Harvest products are designed for **educational** use and are not intended for use in industrial, medical or commercial applications.



WEEE (**W**aste **E**lectrical and **E**lectronic **E**quipment) Legislation

Data Harvest Group Ltd is fully compliant with WEEE legislation and is pleased to provide a disposal service for any of our products when their life expires. Simply return them to us clearly identified as 'life expired' and we will dispose of them for you.